

Turret Winders

The **TREW series** is our most versatile and compact series of automatic turret winders capable of handling multiple types of webs such as films, foils, paper and nonwovens.

This **TREW series** center driven turret winder is equipped with AC Vector drives mounted at each mandrel position. The drives are coupled through a pneumatically counterbalanced dancer roll, for tension control. System operation is fully automatic and PLC initiated for continuous operation. Automatic system control is included for turret rotation, flying knife cut & transfer sequence and general system operation.

KEY ADVANTAGES

- Clockwise and Counterclockwise operation.
- Accurate tension and density control over the full roll diameter.
- Compact footprint.
- Innovative index drive system.
- The carriage is supported by linear bearings for a smooth splicing and transfer.
- Can operate in minimum gap or pressure controlled mode of operation.
- Custom winding solutions are also offered.

MACHINE ACCESSORIES

- Slitting knives
- Shaft and Roll handling
- Pneumo-hydraulic guiding system.

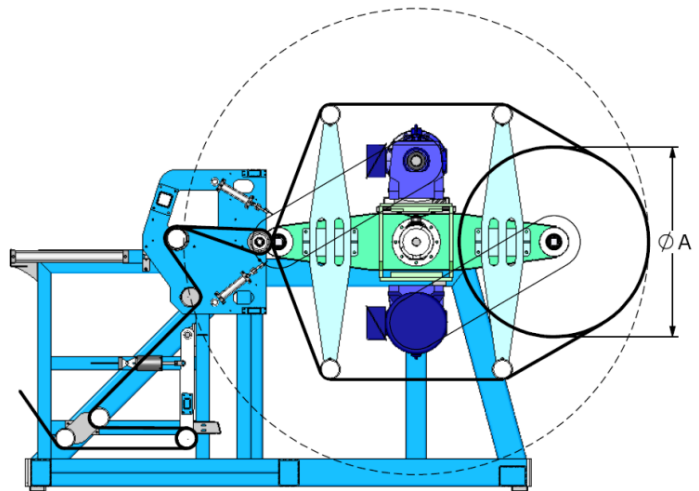
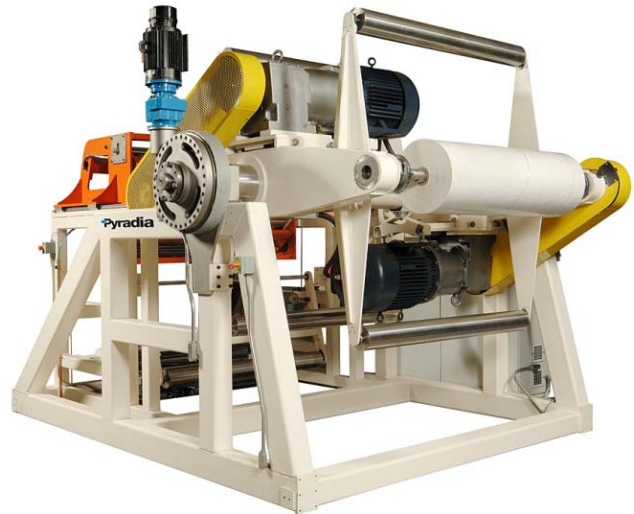

MODEL	MAX ROLL DIAMETER (A)	MAX ROLL WEIGHT	MAX WEB WIDTH	MAX SPEED
TREW 40	40" (1000 mm)	3500 lbs (1600 kg)	84" (2100 mm)	2000 fpm (600 mpm)
TREW 48	48" (1200 mm)	5900 lbs (2700 kg)	132" (3400 mm)	2500 fpm (800 mpm)
TREW 60	60" (1500 mm)	10000 lbs (4500 kg)	156" (4000 mm)	3000 fpm (900 mpm)



430, Guimond
Longueuil [Québec]
Canada J4G 1P8

T 450 463.3344
1 888.PYRADIA
F 450 463.3252